

# ARES 8a Compact footprint. Huge performance.

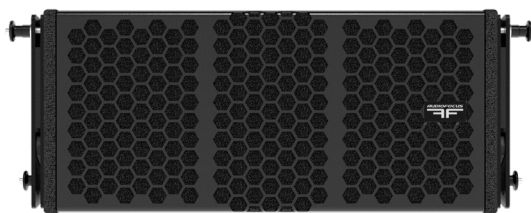

Up to 5,000

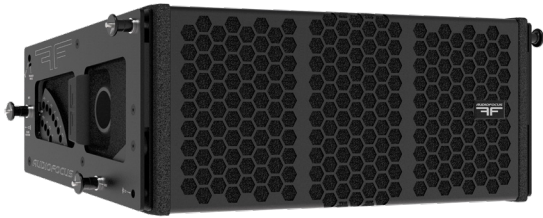

Complete solution



Rigging 0° to 10°



70Hz to 19kHz

ARES 8a is a compact, self-amplified 2-way touring system, renowned for its iconic sound signature in a wide range of sound reinforcement scenarios, from small concerts to theatre and stadium shows.

AUDIOFOCUS ARES 8a meets all WST criteria and offers the full benefits of a true line array. Dual 8" drivers handle low-mid frequencies, while a 1.4" exit compression driver coupled to a waveguide provides smooth high-end performance.

An advanced AUDIOFOCUS SCiO Class D amplifier module with integral DSP and 4 versatile presets allows ARES 8a to be quickly deployed in any configuration. The smart ARES rigging system lets a single operator set up an 8-element system in just 10 minutes, with angles ranging from 0° to 10° with a 0.5° step. ARES 8's lightweight construction and tough rubber handle make the system easy to carry, while magnetic pins cut out vibration.

ARES 8a is built with pride in Belgium and coated in tough, weather-resistant polyurea to safeguard your investment. The cabinet front is protected by a rigid metal grill, backed by acoustically transparent foam.

## Technical specifications

## Dimensions

Description	2-way self-powered full-range line array element
Transducers	LF: 2 x 8" • HF: 1 x 3"
Frequency range (-6dB)	70Hz-19kHz
Nominal directivity (-6dB)	Horizontal 110° - Vertical: depends on the number of elements and array curvature.
SPL max (1)	142 dB
Processing	Dedicated AUDIOFOCUS presets
Rigging	20 different inter-cabinet angle positions, from 0 to 10°
Audio connectors	IN: 1x3-point XLR • LINK: 1x3-point XLR
Network Connectors	1 x etherCON for control
Power Connectors	IN: 1x3-point powerCON TRUE1TOP LINK: 1x3-point powerCON TRUE1TOP
Dimensions (Including Rigging H x W x D)	244 x 643 x 396 mm • 9.61 x 25.3 x 15.60 inches
Weight	30kg / 66.13lbs
Finish	Highly resistant polyurea coating
Cabinet	High grade birch plywood

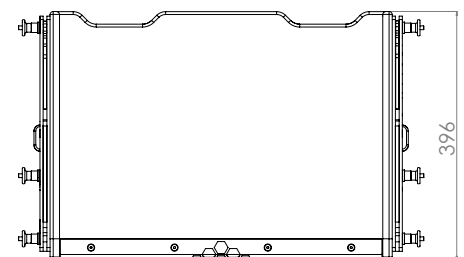
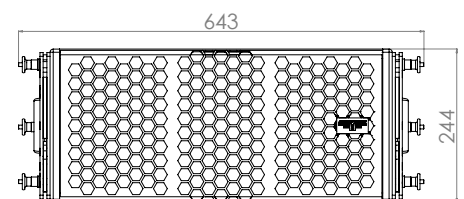

(1) Peak level measured at 1 m under free field conditions using pink noise with crest factor 5

## Rigging accessories

**Bumper for ARES 8a and B 18a**

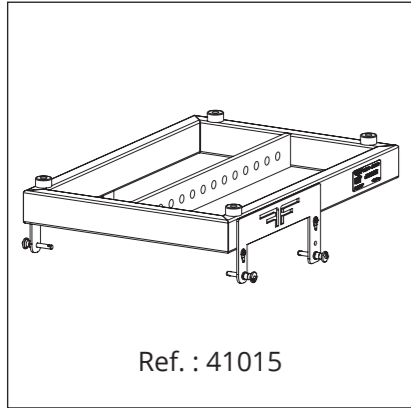

**Mini-bumper for ARES 8a**

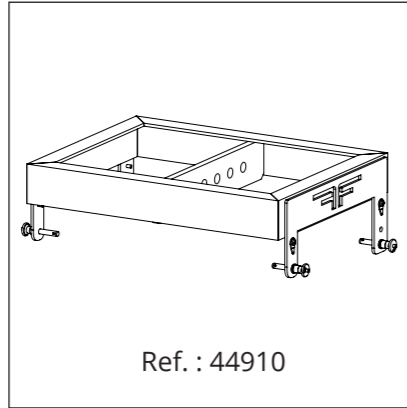

**T-Yoke for ARES 8a**

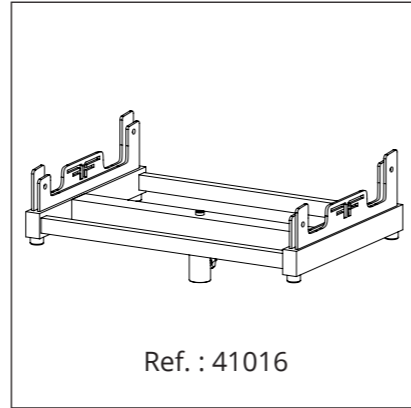

**Overhat for ARES 8a**

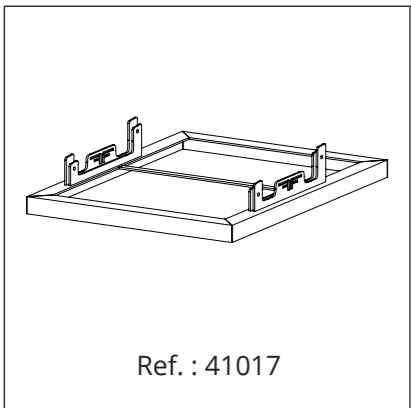

**Protection cover for ARES 8**



## Subwoofers

**S 18a**

Touring high performance self-powered 18" subwoofer.



**S 21a**

Touring high performance self-powered 21" subwoofer.



**B 18a**

Flyable, self-powered 18" touring Low-end extension. Fully compatible.



## Flight Cases

**Flight-case for 2 ARES 8**



**Flight-case for 3 ARES 8**

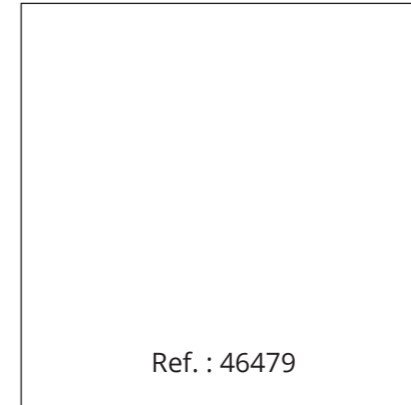

**Flight-case for 3 ARES 8 with flying frame (not included)**



**Flight-case for 4 ARES 8**



**Flight-case for 4 ARES 8 with flying frame (not included)**

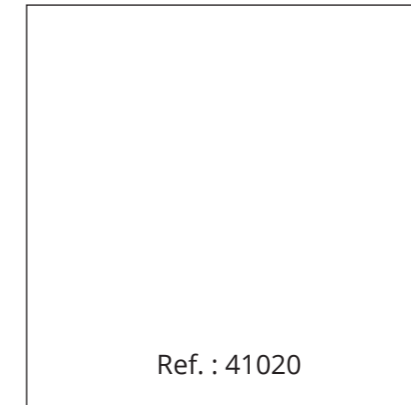

**Flight-case for 2 flying frame ARES 8**



**Flight-case for 2 mini flying frame ARES 8**



## Software



### SCiO

#### *Connect & Control your amplifiers*

AUDIOFOCUS SCiO amplifiers can be securely monitored and controlled anytime, anywhere over the network.

Our intuitive Web UI network manager is web-based, eliminating the need for software downloads, and allows multiple amplifiers to be managed from your preferred device.

The network manager offers the comprehensive processing options you would expect from a high-end system controller.

For more detailed information **please visit the [AUDIOFOCUS SCiO page](#)**.

## Beamwidth

### ARES 8a Horizontal beamwidth

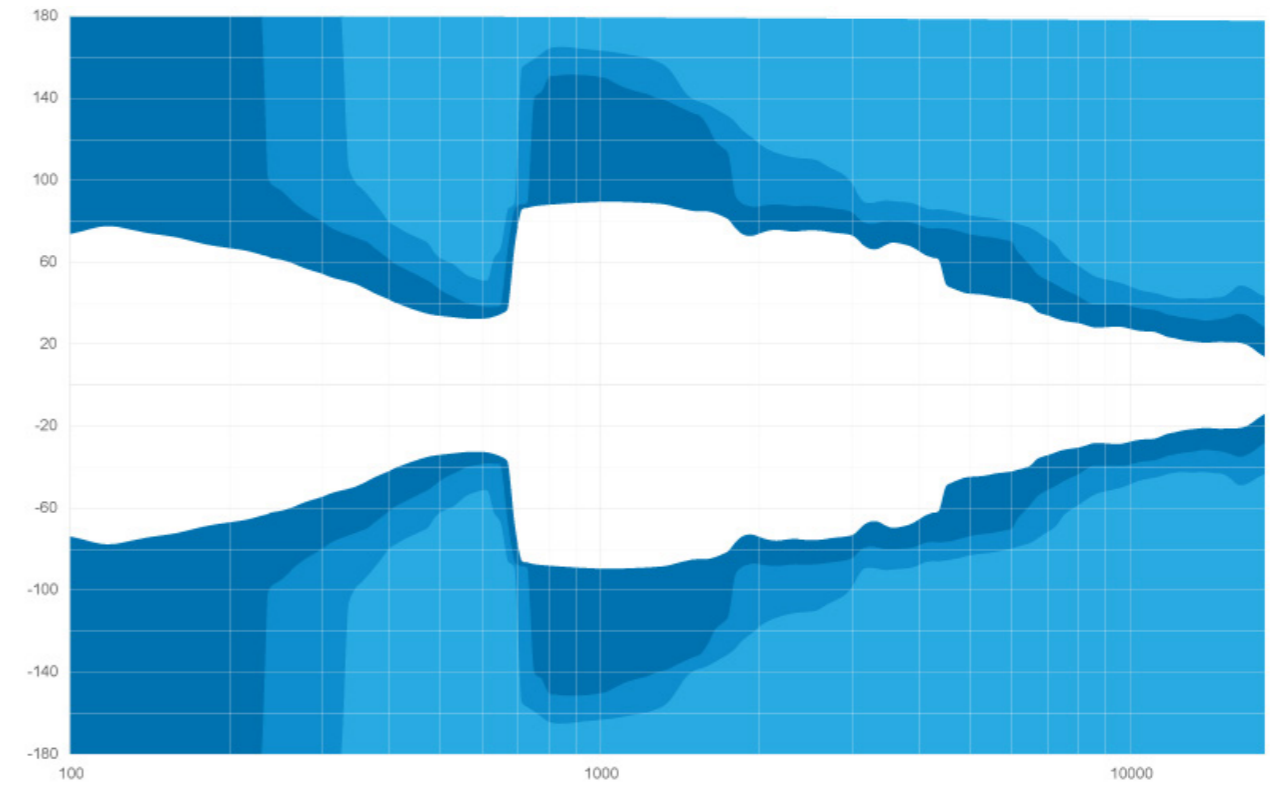

### ARES 8a Vertical beamwidth

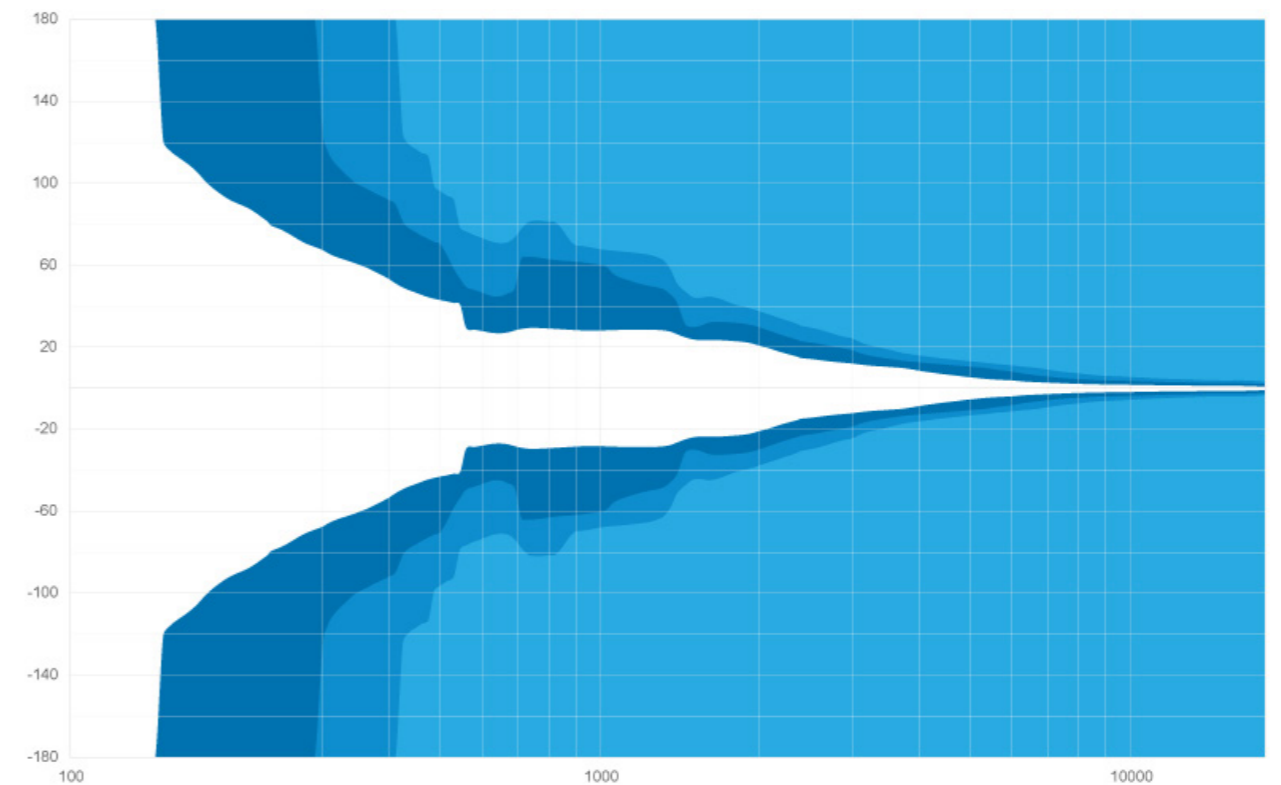

## Contact & Links

---

### Need more information about our products ?

[www.audiofocus.eu](http://www.audiofocus.eu)

[info@audiofocus.eu](mailto:info@audiofocus.eu)

[www.facebook.com/AudiofocusPage/](https://www.facebook.com/AudiofocusPage/)

[www.facebook.com/groups/AUDIOFOCUS/](https://www.facebook.com/groups/AUDIOFOCUS/)

Scan QR Code to view the ARES 8a product's web page.



Follow Us.

