

ARES 8i

Compact footprint. Huge performance

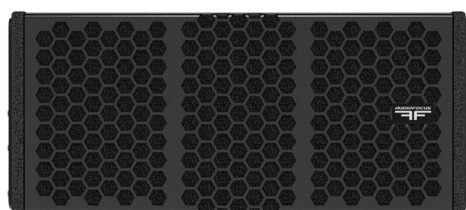

Up to 5.000

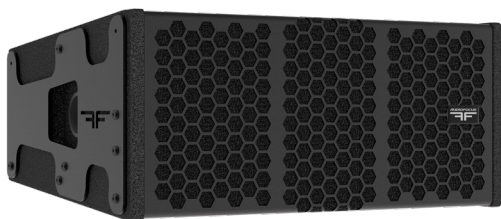

Complete solution



Rigging 0° to 10°



70Hz to 19kHz

ARES 8i is a compact, bi-amplified 2-way installation system, renowned for its iconic sound signature in a wide range of sound reinforcement scenarios requiring excellent audio quality, from smaller venues to theatres and stadiums.

AUDIOFOCUS ARES 8i meets all WST criteria and offers the full benefits of a true line array. Dual 8" drivers handle low-mid frequencies, while a 1.4" exit compression driver and custom waveguide provide smooth top-end performance.

ARES 8i can be quickly deployed in any configuration when used with AUDIOFOCUS SCiO amplifiers with integral DSP and dedicated presets. Armonia presets are also available for Powersoft amplifiers.

A cost-effective rigging system provides a discreet solution for permanent installation.

ARES 8i is built with pride in Belgium and coated in tough, weather-resistant polyurea to safeguard your investment. The cabinet front is protected by a rigid metal grill, backed by acoustically transparent foam.

Technical specifications

| | |
|----------------------------|------------------------------------------------------------------------------------|
| Description | 2-way bi-amplified install line array element |
| Transducers | LF: 2 x 8" • HF: 1 x 3" |
| Frequency range (-6dB) | 70Hz-19kHz |
| Nominal directivity (-6dB) | Horizontal 110° - Vertical: depends on the number of elements and array curvature. |
| SPL max (1) | 142 dB |
| Processing | Dedicated AUDIOFOCUS and Armonia/Powersoft presets |
| Rigging | 11 different inter-cabinet angle positions, from 0 to 10° |
| Connectors | 2 x 4-point speakON |
| Nominal impedance | LF: 16ohm • HF: 8ohm |
| Watt AES/Peak | LF: 400/1600 W • HF: 110/440 W |
| Dimensions (H x W x D) | 244 x 559 x 396 mm • 9.61 x 22 x 15.60 inches |
| Weight | 27.8kg / 61.28lbs |
| Finish | Highly resistant polyurea coating |
| Cabinet | Top grade birch plywood |

(1) Peak level measured at 1 m under free field conditions using pink noise with crest factor 5

Dimensions

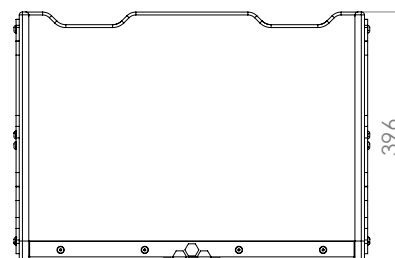
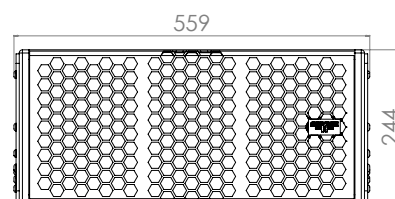

Rigging accessories

Bumper for ARES 8i and B 18i

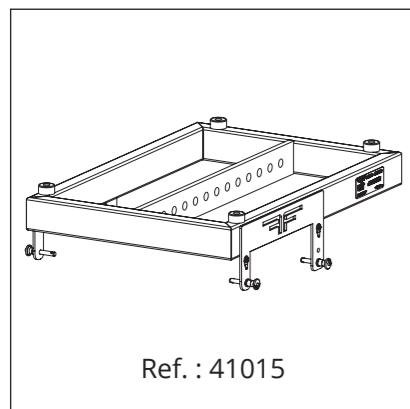

Mini-bumper for ARES 8i

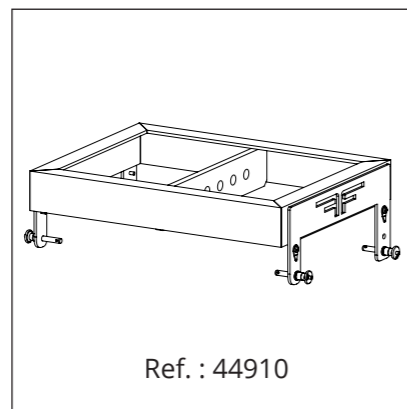

Subwoofers

S 18i

Installation high performance compact 18" subwoofer.



Ref. : 48102 and 48101

S 21i

Installation high performance compact 21" subwoofer.



Ref. : 48105 and 48103

B18i

Flyable 18" installation low-end extender. Fully compatible.



Ref. : 44322 and 44323

Beamwidth

ARES 8i Horizontal beamwidth

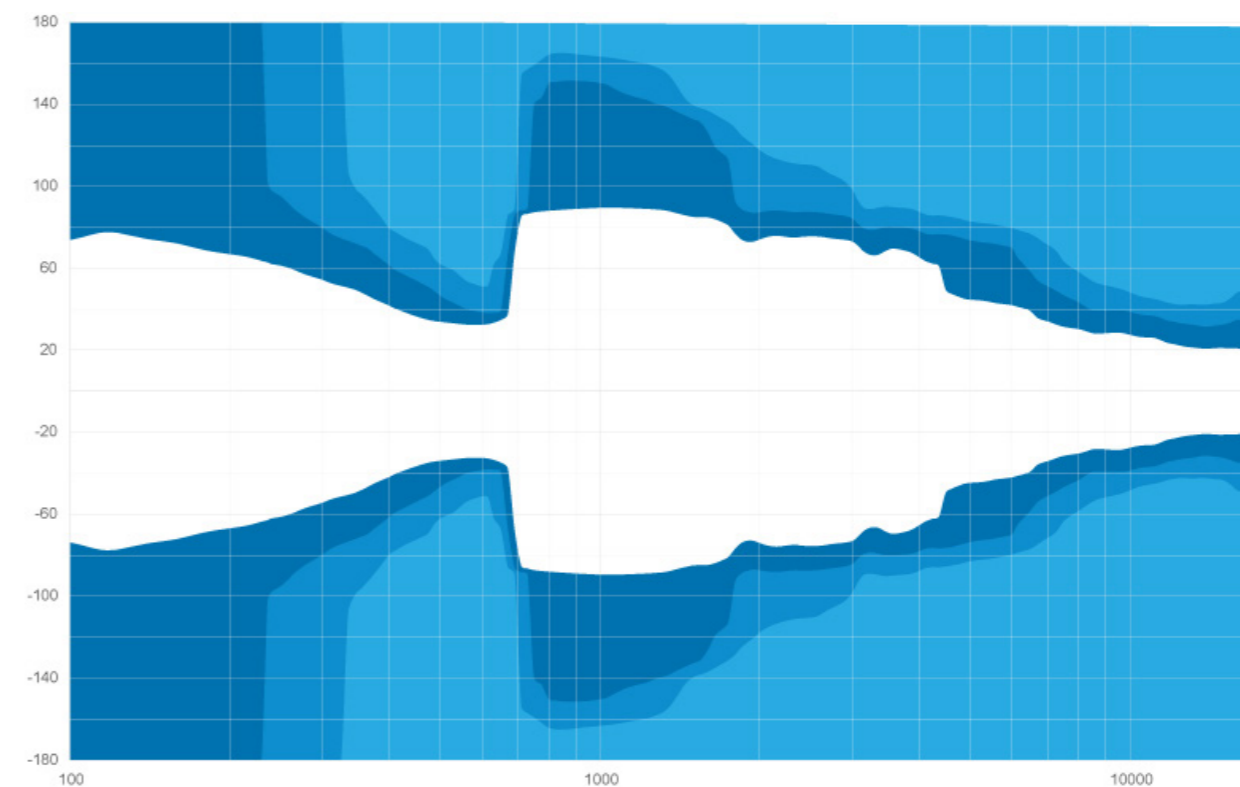

ARES 8i Vertical beamwidth

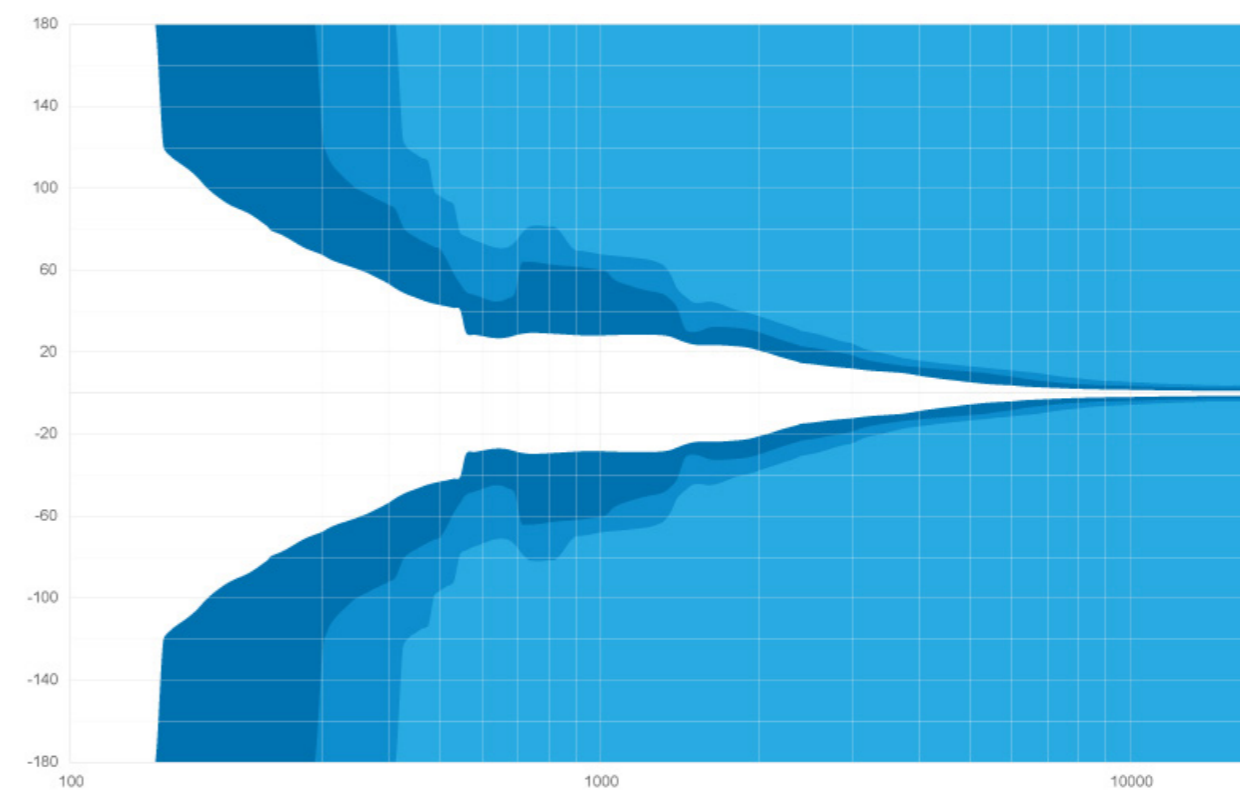

Contact & Links

Need more information about our products ?

www.audiofocus.eu

info@audiofocus.eu

www.facebook.com/AudiofocusPage/

www.facebook.com/groups/AUDIOFOCUS/

Scan QR Code to view the ARES 8i product's web page.



Follow Us.

